

MOVE ON DISCOVERY

AT ROMOSO, WE DESIGN PRODUCTS THAT SET FORTH EXAMPLES OF SHEER CREATIVITY, PASSION, AND AN IMMENSE AMOUNT OF HARD WORK.

INCORPORATING ADVANCED TECHNOLOGY AND HIGH-QUALITY MATERIAL INTO OUR ENTIRE PRODUCT IS WHAT MAKES US THE LEADERS IN THE CERAMIC INDUSTRY. ALL OF OUR DESIGNS ARE MADE TO SUIT THE AESTHETIC OF YOUR SPACE.

THEY ARE REFINED, CONTEMPORARY, AND BUILT TO PERFECTION. OUR DESIGNS ARE INTRICATELY MADE AND BEAR AN IMPERIAL CHARM TO THEM.



A NEW DIMENSION
TO YOUR SPACE.

A MIX OF
CONTEMPORARY
AESTHETICS
AND TIMELESS
ELEGANCE



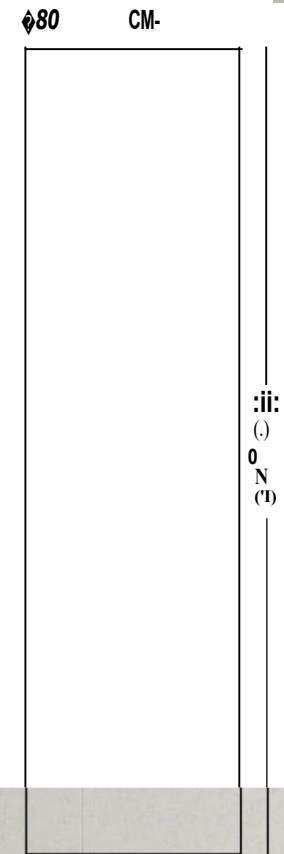
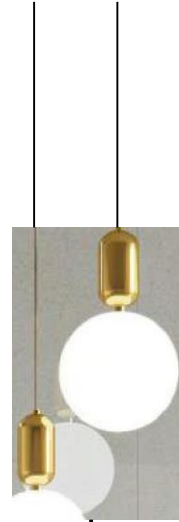

DISTINCTIVE PERSONALITIES

*I
I
I
I*

A COMPLETE PRODUCT SYSTEM

A NEW DIMENSION TO YOUR SPACE.

1. @ FACADES

2. • FLOOR & WALL

3. □ FURNITURE

4. W OUTDOOR

5. □ COUNTER TOPS

6. (§) SINKS

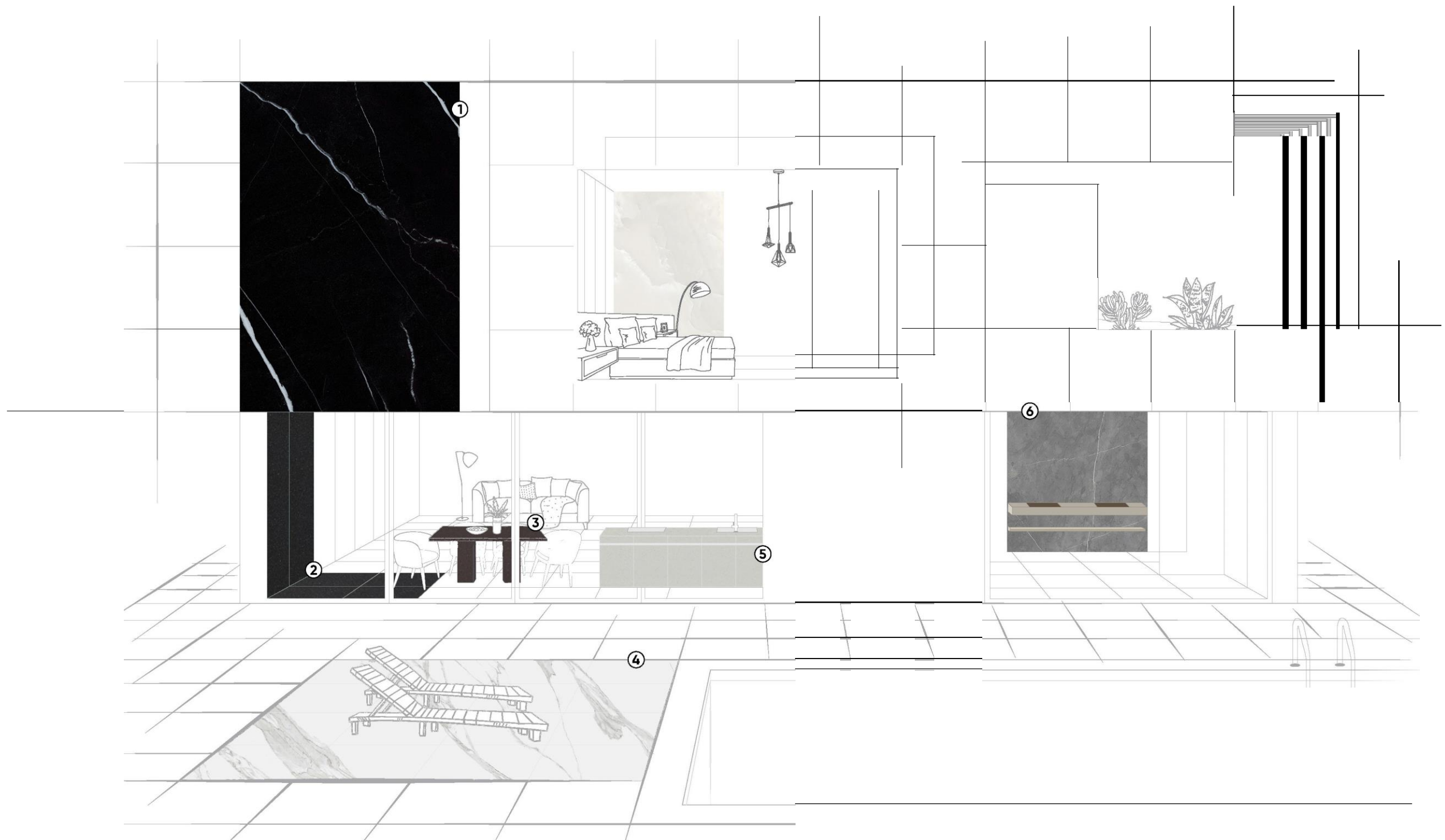

ENVIRONMENTAL SUSTAINABILITY



A NEW DIMENSION
TO YOUR SPACE.

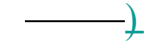

EXTRA
SIZE

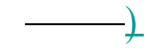

HEAT
RESISTANT

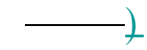

FROST
RESISTANT

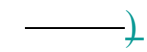

SCRATCH
RESISTANT

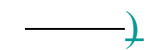

ACID AND
ALKALI
RESISTANT

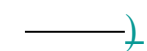

STAIN
RESISTANT

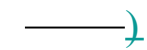
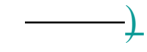

WATERPROOF
AND
ANTI-BACTERIAL
NON-POROUS
AND MILDEW
RESISTANT

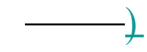

LOW
MAINTENANCE

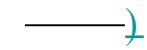

CHEMICAL
RE

EXTRA
GLOSS
✦ ✦ ✦



Note: We illuminate the tile with additional lighting to showcase a sparkling effect. Therefore, we kindly request you to assess the actual piece for precise color representation before making the final decision on the product.

MARQUINA

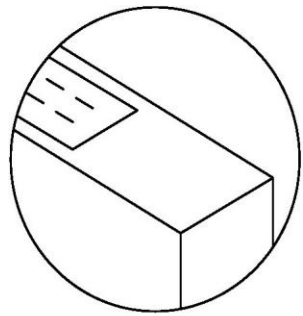

MARQUINA

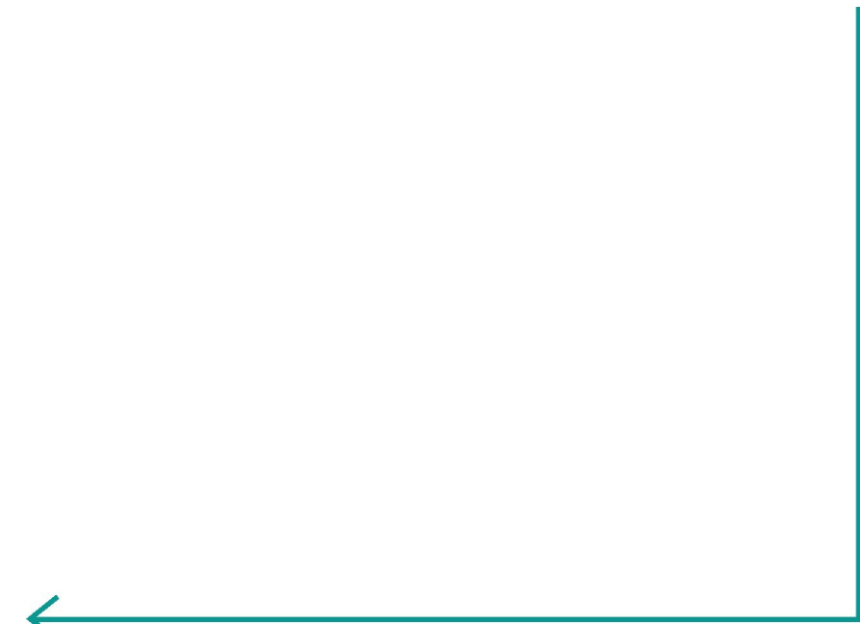

ENHANCE THE BEAUTY OF
YOUR KITCHEN WITH THE EXQUISITE
CHARM OF OUR SLAB TILES,
CREATING A TRULY
STUNNING CULINARY SPACE.



FULLBODY
15MM



**EXTRA
GLOSS**

|

MARQUINA

|

800 X 3200 MM

I
I.J.i
h
4.
DIMENSION TO YOUR
NEVV



I^I
I

I

I

I

EXTRA
GLOSS

+*f*



Note: We illuminate the tile with additional lighting to showcase a sparkling effect. Therefore, we kindly request you to assess the actual piece for precise color representation before making the final decision on the product.

ONYX WHITE

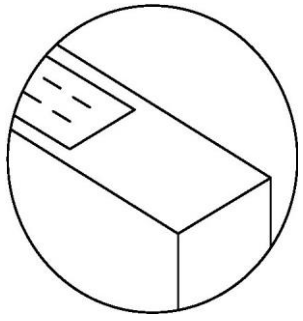

ONYX WHITE



EVITALIZE YOUR BATHROOM WITH THE EXQUISITE ELEGANCE OF OUR SLAB TILES, CREATING A STUNNING SPACE THAT EXUDES BEAUTY AND LUXURY.

DIMENSION TO YOUR
"V.
-Z.
S' < ACΞ. ,



Enchantment Year of Chemistry
BIRDS
HNARA ERDARA
WELCOME BRAGGSVILLE
INSTRUMENTAL NUMBER BUILDING
THE BOX
DESIRE OBTAIN CHERISH
PORTRAIT DE L'ARTISTE EN
SHOWROOM
ISSUE TWO 2007

NATIONAL PARK
THE BIRDS
THE BOX
Java actually

ERIK SATIE
THREE

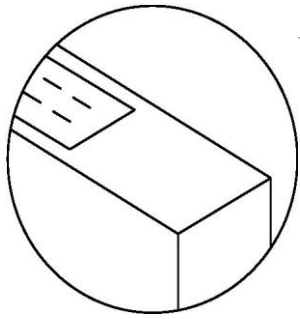

WHITE



ELEVATE YOUR WORKSPACE TO
NEW HEIGHTS OF BEAUTY
WITH OUR STUNNING TILES, INSPIRING
CREATIVITY AND SOPHISTICATION.

u

DIMENSION TO YOU



CARS

VOGUE
KAYE MOSS
AMERICAN FASH

AMERICAN FASH

EXTRA
GLOSS



PIETRA GREY

Note: We illuminate the tile with additional lighting to showcase a sparkling effect. Therefore, we kindly request you to assess the actual piece for precise color representation before making the final decision on the product.

I A NEW DIMENSION
4.
4' / 0A 0-

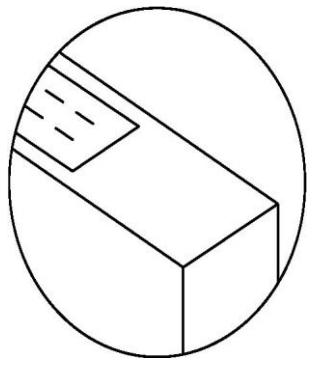

PIETRA GREV



ENHANCE THE ALLURE OF YOUR
SHOWROOM WITH THE
EXQUISITE BEAUTY OF OUR TILES,
TRANSFORMING IT INTO A
CAPTIVATING SPACE.



FULLBODY
15MM



**EXTRA
GLOSS**



PIETRA GREV

800 X 3200 MM

A NEW DIMENSION TO YOUR SPACE.





FULLBODY
15MM



EXTRA
GLOSS



↓

STATUARIO CARARA

↓

800 X 3200 MM

A NEW DIMENSION TO YOUR SPACE. →



